



Natural Draft Solid Fuel Heater Operating and Installation Instruction Manual



Cozy Cabin Solid Fuel Heater

** Please read from beginning to end before installing and operating.

Quality Controlled by- Doug & Don
Form#7.2-230 Issue#1 March 3, 2010

Table of Contents

Table of Contents...	Pg. 2
Warnings...	Pg. 3
1. About a Natural Draft Solid Fuel Heater...	Pg. 3
2. Important Notes...	Pg. 3
3. Ventilation...	Pg. 4
4. How does the Chimney affect the Heater...	Pg. 4
- Testing your Draft...	Pg. 6
- Downdraft...	Pg. 6
5. Installing your Heater...	Pg. 6
- Location...	Pg. 6
- Safety Clearances...	Pg. 6
- Mounting...	Pg. 6
- Location Diagrams...	Pg. 7
- Chimney Pipe...	Pg. 7
- Chimney Pipe Diameter...	Pg. 7
- Barometric Damper...	Pg. 8
- Deck Fitting...	Pg. 9
- Deck Fitting Diagram...	Pg. 9
- Exhaust Cap...	Pg. 9
- Heater Installation Diagram...	Pg. 10
6. Heater Operation...	Pg. 11
- Fuel...	Pg. 11
- Lighting Procedure...	Pg. 11
- Exterior Surface...	Pg. 11
7. Warranty...	Pg. 12
8. Registering your Warranty...	Pg. 15

WARNINGS

- Do not operate this heater unattended.
- When operating the heater there **MUST** be an open fresh air vent.
- Do not attempt to burn oil or gas fuels in this heater.
- Do not overfill the combustion chamber.
- Install a CO alarm.
- Do not operate this heater if you are experiencing downdrafts.
- **WARNING:** This heater and exhaust pipe gets very hot during operation, use hand protection and caution.
- Follow **ALL** installation and operation procedures.

1. About a Natural Draft Solid Fuel Heater

This bulkhead mounted solid fuel heater is a reliable yet beautiful source of heat. The maximum output of this heater is meant for 8000 btu's. This heater is designed to heat a small area or as an esthetic feature of your boat. Combustion options include a 1" piece of wood, a handful of charcoal briquettes, peat, coal or presto log. Over filling of the combustion chamber can cause damage to the heater. Built-in manual damper and ash drawer lock included.

To obtain a clean and efficient combustion, 3 factors must be in a balanced proportion.

1. **Draft**- the volume of air rising through the exhaust chimney.
2. **Oxygen**- replacement supply of fresh air.
3. **Fuel**- Input in proportion to the supply of draft and oxygen.

2. Important Notes

Here are some important notes to remember when planning and/or installing a Sig Marine solid fuel heater:

- Mounting & location, minimum 4ft and a maximum 10ft of chimney, and the location of hole for the chimney.

- **Unrestricted permanent fresh air inlet required to draw in outside air needed for correct operation.**
- A barometric damper must be installed to help regulate the draft. A barometric gives you more control in the “fuel to air” mixture needed for correct combustion. (See Pg. 8).

3. Ventilation

You **MUST** replace the air inside your boat at the same rate that the heater is removing it. The higher the heater’s burning rate, the more air the heater will require. If the air flow is blocked or restricted, the heater will burn inefficiently, create soot, blow out and can be a health hazard.

A permanently open fresh air inlet **MUST** be installed or dedicated to the heater. This inlet must be at least 3" in diameter. Ducting fresh air to the heater is also an option. It is important to create and maintain a positive pressure inside the boat. High winds can draw air out from the boat and thus create a negative pressure. This condition can result in down drafts. Ensure that when you do have windows open that they do not create a suction effect in the cabin due to the window’s position and the wind direction. In a similar way, it is possible for the air intake on your engine to suck the air out of a cabin if it is not properly vented.

Your heater is a natural draft appliance and it creates its draft pressure like a chimney in a wood stove. The rising, heated air in the chimney pulls fresh air into the heater as it rises up the chimney and exits the flue cap. The greater the draft pressure, the more able the heater will be to resist strong winds, overcome flue elbows that inhibit draft and the hotter you will be able to get your heater without sooting. A CO alarm should be installed in the boat.

4. How Does the Chimney affect the Heater?

The heater does not create the draft for a natural draft appliance to operate; it is the chimney that creates the draft for operation. The purpose of a chimney is to take the combustion products (smoke and gasses) from the appliance to the atmosphere outside your boat, and at the same time, to draw air in for

combustion into the appliance. This movement of combustion air and exhaust is called draft.

In essence, it is the difference in pressure between the air inside the chimney flue and the outside air that creates this movement. Warmer, lighter gasses in the flue tend to move upward.

To keep the pressure conditions favorable, we need a tall column of warm air inside the chimney, and cooler air outside. The warm air will tend to rise, drawing the exhaust from the appliance out. As air exits the chimney, fresh air for combustion is drawn into the appliance. The stronger the upward draft in the chimney the more likely you won't experience downdraft.

Important Factors of the Chimney

Since draft is a measure of pressure, chimney draft is affected by pressure conditions in the boat. Several factors come into play:

1. **Adequate air.** First, there must be adequate air movement into the boat to make up for the air exiting through the chimney. If the boat is very tightly insulated, the volume of air drawn up the flue will exceed the volume of air entering the boat, and the boat will gradually become depressurized. With lower pressure in the boat than outside, there will be a tendency for air to be drawn into the boat from all available openings including down the chimney.
2. **Air movement in the boat.** Second, air movement in the boat must not interfere with the chimney. The entire boat then becomes like a big chimney. As air flows out through the one window, air is drawn from another to replace it. This is called the stack effect, since the boat acts like a stack, or chimney. If the stack effect is powerful enough, it will overcome the chimney's upward draft and pull replacement air (and smoke) into the boat through the chimney.
3. **Competition for available air.** Third, there must not be too much competition from other devices in the boat, such as exhaust fans, a large engine or air-exchange systems. If something else is sucking the air out of the boat, the chimney might not be powerful enough to overcome it, and exhaust might be drawn into the boat from the chimney.
4. **Proper chimney design.** And finally, a chimney must be designed to accommodate the volume and type of exhaust being emitted by the

appliances it serves. This involves correct sizing, adequate height, and proper construction. See the “Chimney Pipe” section on pg. 7.

Since the chimney draft is affected by so many factors, draft problems can be complicated to find.

Testing the Draft

To find where the air is being drawn, twist a paper towel into a wick, light it and blow it out to create smoke. Placing the smoking wick near the open hatches, windows or vents will lead you to the location. Installing or opening opposing vents will allow the air to come in from a path of least resistance and not disturb the draft in the chimney.

Downdraft

A common reason for downdraft is burning the heater too low (too much air in the combustion chamber and not enough fuel). If the flames are weak then it is burning inefficiently causing the draft to be too weak going up the chimney allowing downdraft down the chimney. When the flames are burning strong then the natural draft is at its strongest so it can fight against downdraft.

5. Installing your Heater

Location

Plan your heaters location prior to installing to ensure the location chosen will fit the specifications and safety clearances. Combustible material closer to the heater than the specified safety clearances must be lined with insulation or millboard and a metal liner with a .5” standoff for air movement behind. Another alternative is using insulation or millboard and ceramic tile. The back of the heater and the first length of chimney pipe should also be lined with such material. See diagram below.

Safety Clearances

All sides- 8”

Mounting

The heater has the appropriate brackets attached to secure the heater to the bulkhead. Locate the heater as close to the floor as possible for maximum stack length and to provide good heat convection. The location must also

take into consideration stack configuration and insure that the chimney above deck is clear of any obstruction.

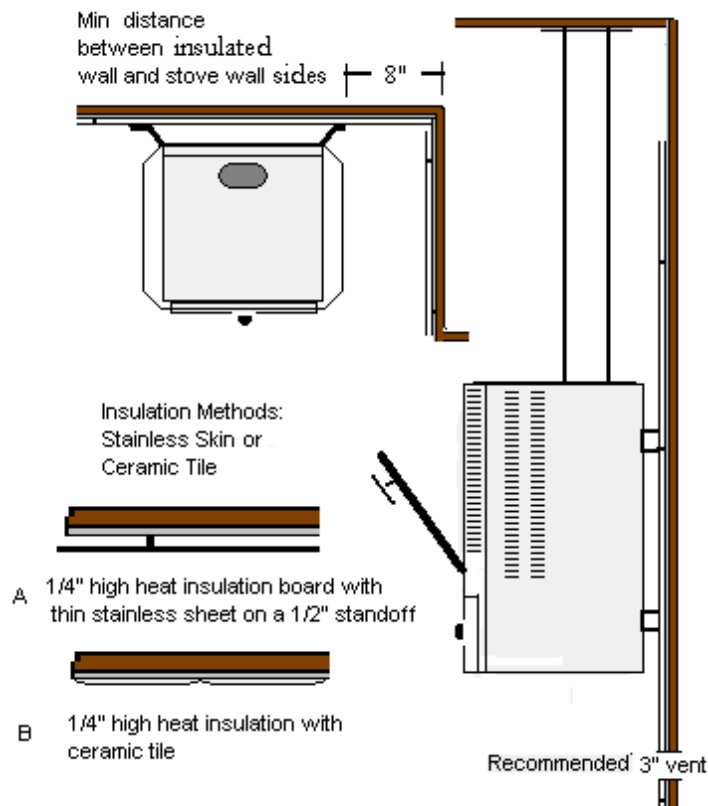

Chimney Pipe

The location and configuration of the chimney stack is very important to the operation of the heater. A long, straight chimney stack will ensure a strong draft for correct operation. The diameter of the chimney must be what is specified. We recommend that the length of your chimney is a straight 5-6ft run with a minimum of 4ft long and a maximum of 10ft. Avoid using elbows and if necessary, use 45 degree elbows and allow for as much straight pipe as possible with a minimum of 12" (28 cm) from the top of the heater. There is no connector to connect the chimney pipe to the heater. There is a flue collar already attached to the top of the heater and the pipe can attach by squeezing the pipe into an oval shape and fitting it over the flue collar.

Chimney Pipe Diameter

3" diameter chimney (7.5cm)

Barometric Damper

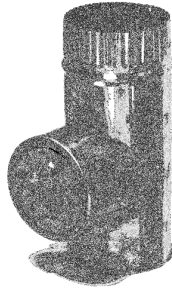

Install the barometric tee pipe with the front flap facing fore and aft. In order for the barometric to work efficiently it must be installed between 12” and 24” from the top of the heater.

We have 2 options for installing the barometric damper into your chimney. You can either have the barometric attached to a 22” stainless pipe to be the first piece of pipe of your chimney off the top of the heater or you can use a 7” piece of pipe that you can fit into your chimney 12” to 24” from the top of the heater.

Part# 16-001: 3” x 22” stainless pipe with barometric

Part# 16-010: 3” x 7” stainless pipe with barometric

The barometric damper should be installed in oil and solid fuel heaters and stoves. The purpose is to maintain a strong draft without causing too much air to the “fuel to air” mixture. When the damper is adjusted, the draft is altered by allowing air to be pulled into the chimney by the air inlet on the damper and not pulled into the burner. This gives you more control. Having a barometric allows you to burn your heater at lower temperatures giving you the control to adjust the draft once the fuel is adjusted to ensure a clean burn.

To adjust the flap on the barometric, back off the jam nut and turn the counterweight so the flap is standing closed. Once the heater has been burning for some time and the room temperature is starting to rise, it is a good time to do the adjustment. Adjust the counterweight so the flap starts to open (aprox 6mm or 1/4”). This will allow air to enter the barometric tee and reduce the air entering the combustion chamber.

Deck Fitting

To install the thru deck fitting, a hole must be cut in your deck. There should be a 1" clearance all around the chimney pipe. The 3" diameter exhaust pipe would require a 5" hole drilled in the deck. Once a hole is cut, you can line the raw hole with epoxy, caulking or a metal liner to finish it off. Just ensure there is a 1" air gap between the hole and the chimney pipe.

The thru-deck fitting includes a stainless steel dress ring for the interior of the cabin and a neoprene rubber gasket to better seal the fitting. Depending on the contour or the angle of the cabin top, you may need to make a hardwood spacer block. One surface of the block would be a level plane to mate to the deck cap. The other would match the angle or contour of the cabin top. A hole through the center of the block would also be 2 inches greater than the diameter of the flue pipe.

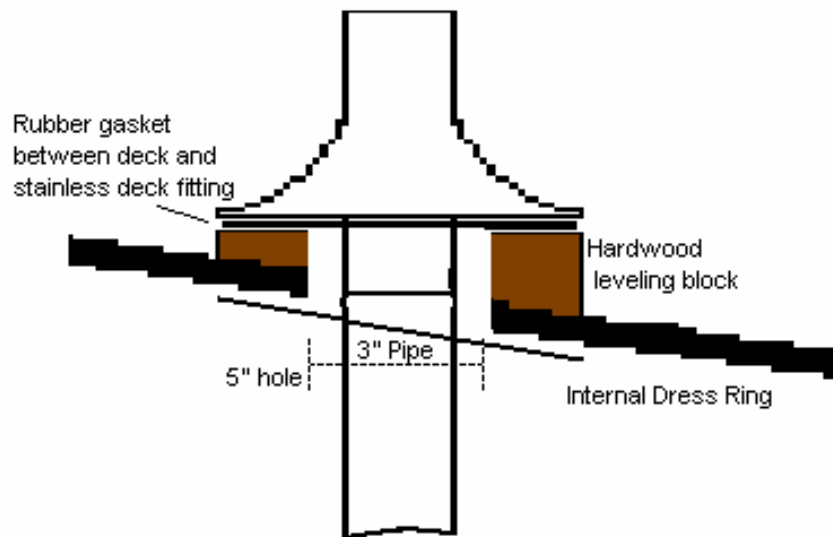

Exhaust Cap

The Dickinson DP or H style exhaust caps are most recommended. The exhaust cap will fit over the crimp on the deck fitting or flue pipe. The location of the exhaust cap above deck must be clear of any immediate obstruction that may cause unusual air movement or turbulence. **CAUTION:** The Exhaust Cap gets hot when the stove is operating.

Heater Install Diagram

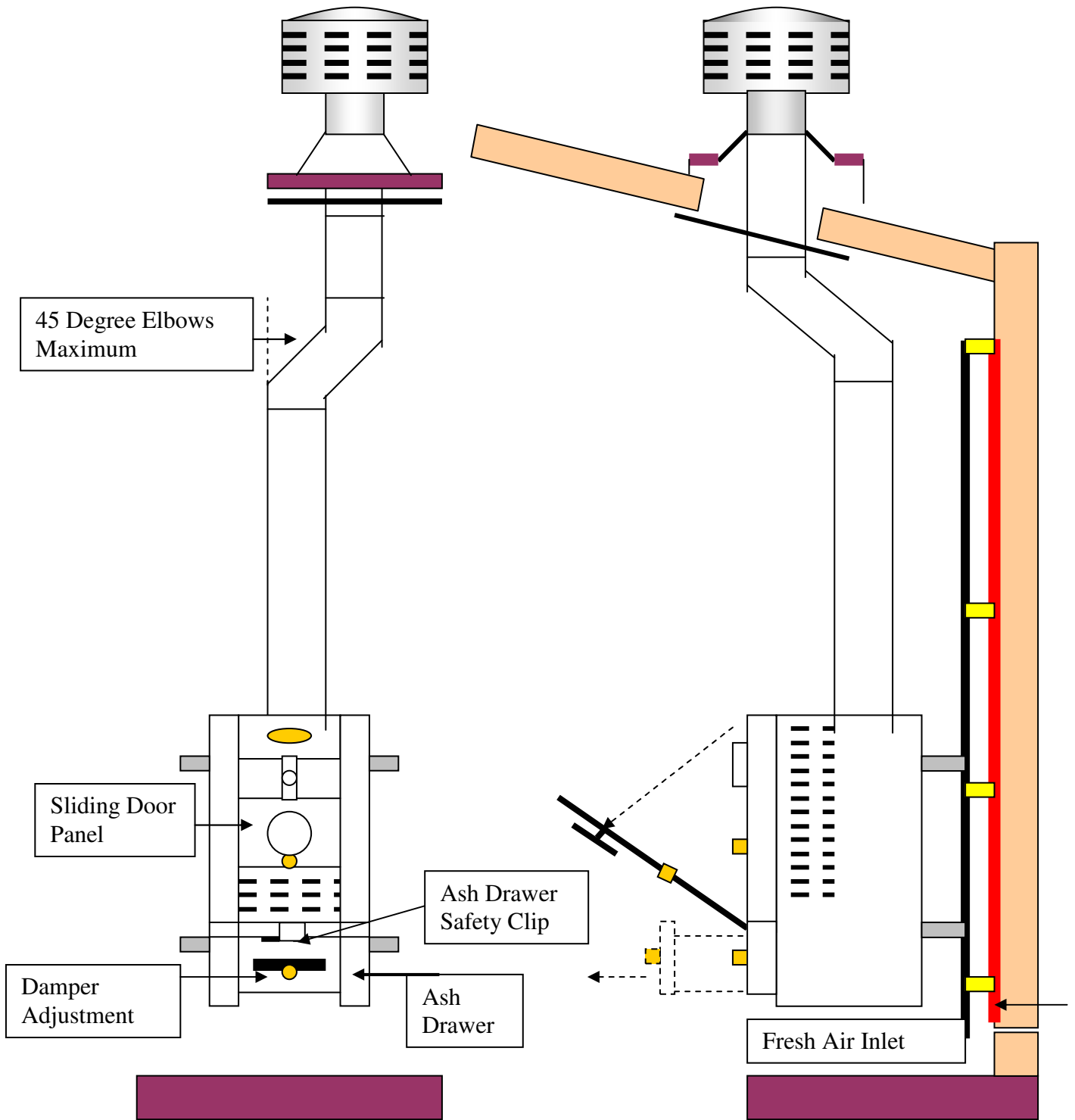

6. Heater Operation

Fuel

Combustion options for this appliance are wood, charcoal briquettes or similar solid fuels that can be burned. Slow burning fuels are recommended. Care must be taken not to overfill the combustion chamber as this can damage the heater. The heater is rated for approximately 8000 btu's. This will be equal to a small handful of briquettes, 1 or 2 slices of presto logs at 1" thick or equivalent sizing for wood or other solid fuels.

Certain brands of engineered firewood can burn with an enhanced level of heat so caution must be used. Refrain from burning any manufactured wood with an artificially increased btu rating. When using engineered firewood, cleaning of the firebox and exhaust chimney may be required.

Lighting

- 1) Open the damper control on the front of the ash drawer by sliding the brass knob to the right.
- 2) Close the sliding panel on the front door of the heater.
- 3) The fire can be lit using any fire lighter or starter. **IT IS IMPORTANT NOT TO OVERFILL THE COMBUSTION CHAMBER.**
- 4) Once the fuel has ignited the sliding panel may be opened and the damper control adjusted to provide extended burning. **WARNING:** Both the knob of the sliding door and the damper are hot and hand protection must be worn to make any adjustment when the heater is burning.
- 5) Lift off the ash drawer clip lock to remove the tray for emptying.

Exterior Surface

Little maintenance is needed for stainless steel. There are many stainless steel cleaners available and these may be applied as needed. An abrasive scotch bright pad can be used to remove burn discoloration or surface scratches by rubbing parallel to the grain of the brushed metal.

7. Warranty Policy

We at Sig Marine wish to maintain a reasonable and easy system for returns, warranty, returns and exchanges. To accomplish this, we would like to inform you of some helpful guidelines and procedures to use and follow when sending back product to the Sig Marine. All correspondence regarding returns, warranties and exchanges will go through the factory of Sig Marine in Coquitlam, BC, Canada and the product **MUST** be returned to this location.

Warranty

Sig Marine warranties all of its products for a period of one year dated from the purchase of the product by the end user with proof of purchase or a registered warranty. We warrant our barbeque burners for a period of 3 years dated from the purchase of the product by the end user. The warranty card should be copied for your records and returned to Sig Marine to activate your warranty within 90 days of your purchase. You can also activate it online at www.sigmarine.com

A copy of the warranty card must have been received or a proof of purchase must be presented to receive the warranty.

1. The customer can contact us directly to settle any warranty issues. We are pleased to help. Call us toll free 1-800-659-9768 or email: info@sigmarine.com
2. If the customer is returning a complete product they see as defective, be sure the product has been assembled correctly and is being used correctly. If you are not sure please call our Technical Help Department @ 1-800-659-9768. Sig Marine will not provide credit for used products that are not defective. In these cases, it is best to call the factory to determine if the product is being used correctly, has been assembled correctly or is in fact defective.
3. All products being sent back to Sig Marine must have a Return Authorization Number. Contact us at Sig Marine toll free 1-800-659-9768 or e-mail info@sigmarine.com to obtain a Return Authorization

Number. This allows us to track and process your return. Once you have received an RA# from us, include your proof of purchase and ship to the address below. We recommend you ship using the mail service insured and retain a tracking number. Customers are responsible for the shipping costs for all returns and exchanges.

Sig Marine Returns
 Unit# 407-204 Cayer Street
 Coquitlam, BC
 V3K 5B1 Canada

4. Products that are older than the warranty period or those that have obviously been misused will not be returned, exchanged, or repaired.

Non-defective Returns & Exchanges

Sig Marine reserves the right to apply a 20% restocking fee for returned product sent back. An RA # will be needed from the factory to facilitate any return. Credits will be made at the last purchased price for that part number.

Limited Warranty

WARRANTY PROVISIONS: Sig Marine warrants this product to be free of defects in workmanship and materials for a period of one year. This warranty is limited to claims submitted in writing within a one-year period following the date of purchase. If any part of your new product fails because of a manufacturing defect within the warranty period Sig Marine offers to replace said parts free of charge, provided, however, that such parts have not been improperly repaired, altered or tampered with or subjected to misuse, abuse or exposed to corrosive conditions. This warranty, however, is limited by certain exclusions, time limits and exceptions as listed below. Read these limitations and exclusions carefully.

TIME LIMIT: This warranty is given too and covers only the original purchaser. Coverage terminates one year from the date of purchase for parts replacement.

EXCLUSIONS : This warranty does not cover or include : (a) Any normal deterioration of the product and appearance of items, due to wear and/or exposure; (b) any guarantees, promises, representations, warranties or service agreements given or made by an authorized distributor or other person selling this product, other than those specifically stated herein; (c) any damage or defect due to accident, improper repair, alteration, unreasonable use including failure to provide reasonable and necessary maintenance, misuse or abuse of the equipment, or exposure to corrosive conditions. This warranty is conditioned upon normal use, reasonable and necessary maintenance and service of your product, and written notice being given promptly upon Buyer's discovery of a warranty

claim, pursuant to paragraph 6 below. Reasonable and necessary maintenance is maintenance which you are expected to do yourself or have done for you. It is maintenance, which is necessary to keep your product performing its intended function and operating at a reasonable level of performance.

DAMAGE LIMITATION WARNING : IN NO EVENT SHALL Dickinson BE LIABLE FOR ANY INCIDENTAL OR CONSEQUENTIAL DAMAGES, INCLUDING (BUT NOT LIMITED TO) LOSS OF USE OF THE PRODUCT, LOSS OF TIME, INCONVENIENCE, EXPENSES FOR TRAVEL, LODGING TRANSPORTATION CHARGES, LOSS BY DAMAGE TO PERSONAL PROPERTY OR LOSS OF INCOME, PROFITS OR REVENUE.

ORAL OR IMPLIED WARRANTY LIMITATIONS: The foregoing warranty is exclusive and in lieu of all other warranties, written or oral, expressed or implied, including but not limited to any warranty or merchantability or fitness for a particular purpose.

TRANSFER LIMITATIONS: This warranty is not assignable or transferable. It covers only the original purchaser.

CLAIM PROCEDURE: In the event of a defect, problem or that a breach of this warranty is discovered, in order to protect any warranty rights you must promptly notify Sig Marine. Give name, address, and model name, location of unit, description of problem and where you can be reached during business hours.

RESERVED RIGHT TO CHANGE: Sig Marine reserves the right to make changes or improvements to products it produces in the future without imposing on itself any obligations to install the same improvements in the products it has previously manufactured.

SECOND OR SUBSEQUENT OWNER: Sig Marine does not give any warranty to secondary or subsequent purchasers, and it disclaims all implied warranties to such owners.

INSPECTION: To assist you in avoiding problems with your product and to validate this warranty you are required to do the following: (a) read the warranty; (b) inspect the product. Do not accept delivery until you have examined the product with your supplier; (c) ask questions about anything you do not understand concerning the product.

OWNER REGISTRATION: Fill out the WARRANTY CARD within 30 days from the date of delivery. **WARRANTY: RETURN OF THE CARD IS CONDITION PRECEDENT TO WARRANTY COVERAGE AND PERFORMANCE. IF YOU DO NOT FILL OUT AND MAIL THE CARD AS DIRECTED, YOU WILL NOT HAVE A WARRANTY.**

LEGAL RIGHTS: This warranty gives you specific legal rights and you may also have other rights, which may vary within different government jurisdiction

8. Register your Warranty.....

Please register your warranty with Sig Marine. Fill out and send back the warranty registration below.

No warranty will be extended for improper installations. Use of any unapproved materials, equipment, or installation procedures will result in a voided warranty. Do not use any substitutes of the heaters valve, burner or fan other then the ones supplied by Sig Marine. Sig Marine accepts no liability for any damage or loss of service resulting from unapproved modifications.

Warranty Form

I have read and understand the Limited Warranty and the entire Instruction Manual and agree to the terms and conditions. (PLEASE PRINT)

Name: _____

Address: _____

Phone: _____

Heater Model Name: _____

Heater Serial #: N/A _____

Date of Purchase: _____

Seller's Name: _____

Seller's Location: _____

Signature: _____

This warranty form can also be filled out online. www.sigmarine.com

Sig Marine

#101-17728 66 Avenue, Surrey, BC

V3S 7X1 Canada

Tel: 604-574-8641

Fax: 604-574-8659

E-mail: info@sigmarine.com

Website: www.sigmarine.com

All rights reserved. No part of this manual may be reproduced without permission in writing from Sig Marine. Sig also reserves the right to modify or change without notice, any materials, applications, equipment, accessories, and/or prices. All measurements and weights are approximate.