



Direct Draft Propane Heater Operating and Installation Instruction Manual



KEEP THIS MANUAL FOR FUTURE REFERENCE

P9000 & P12000 Model Heaters

** Please read from beginning to end before installing and operating.

Heater's Serial #: _____

Quality Controlled by- Doug & Don

Form#7.2-247 Issue#1 Apr. 8 2011

Table of Contents

Table of Contents & Packing List...	Pg. 2
Warnings...	Pg. 3
1. About a Direct Draft Propane Heater...	Pg. 4
2. Important Notes...	Pg. 4
3. Installing your Heater...	Pg. 5
- Location...	Pg. 5
- Safety Clearances...	Pg. 5
- Mounting...	Pg. 5
- Chimney Pipe...	Pg. 6
- Deckcap Deck Fitting...	Pg. 7
- Deckcap Deck Fitting Diagram...	Pg. 7
4. Connecting the Propane Fuel ...	Pg. 8
- Propane locker diagram...	Pg. 9
- Fuel Connection Options...	Pg. 9
- Electrical 12v Fan...	Pg. 10
5. Lighting Procedure ...	Pg. 11
- Flame Characteristics...	Pg. 11
6. Maintenance...	Pg. 12
- Thermocouple & Orifice Cleaning...	Pg. 12
- Troubleshooting ...	Pg. 13
- Replacement Parts...	Pg. 14
7. Warranty Policy...	Pg. 15
8. Registering your Warranty...	Pg. 18

Packing List

1. P9000/ P12000 Heater Fireplace
2. 2.5" x 28" Double-walled Stainless Exhaust Pipe
3. 2.5" Stainless Deckcap Fitting, Gasket & Dress Ring
4. Stainless wall mounting backing plate

WARNINGS

- This is a low pressure appliance and **MUST** have a separate low pressure regulator installed or operation can result in a dangerous fire or extreme internal damage to your heater.
- Improper use of a gas appliance can result in serious injury, fire, explosion, carbon monoxide poisoning, oxygen depletion or even death.
- Do not operate this heater unattended.
- Turn off the heater when refueling.
- This propane heater requires an installed chimney for correct operation. Do not attempt to operate the heater without the supplied flue chimney installed correctly as required in this manual.
- Do not store or use gasoline or other flammable vapors or liquids in the vicinity of this appliance.
- Do not install this appliance in spaces containing internal combustion engines, fuel tanks, or joints and fittings of their fuel systems.
- All installations must conform with local codes or in the absence of any codes with the current National Fuel Gas Code, ANSI Z223.1 or current CAN/CGA B149, Installation Codes.
- Manufactured or mobile home installation must conform to Manufactured Home Construction and Safety Standard, Title 24 CFR, Part 3280, or, when not applicable, the Standard for Fire Safety Criteria for Manufactured Home Installation Sites and Communities, ANSI/NFPA 501A,(USA) or Mobile Homes Standard, CAN/CSA-Z240 MH Series, in Canada.
- Follow ALL installation and operation procedures.

1. About a Direct Draft Propane Heater

This direct vent propane heater fireplace is a clean burning low pressure propane appliance for use on board small marine vessels and many other different applications.

These heaters are equipped with a stainless double walled vent pipe and deckfitting/ exhaust cap. Fresh air is pulled from outside, through the outer pipe into the combustion chamber while exhaust gas leaves the vessel through the inner pipe. The air from inside the cabin is not being used for combustion so a fresh air vent is not needed. Since, this unit has an isolated combustion, the exhaust gases are being taken out via the chimney so no moisture is being created.

These heaters are equipped with a CGA/AGA approved safety gas valves. If the flame should ever be extinguished the gas will be shut-off automatically. Manual ignition involves lighting the heater with a long barbeque lighter with the door open and therefore avoids any initial build up of unburned gas. The installation of a gas detector is recommended for all LPG appliances.

***NOTE:** When using the P12000 heater on high setting, the fan may have to be used to draw out the heat from the chimney pipe to keep it from sooting the window.

2. Important Notes

Here are some important notes to remember when installing a Dickinson direct draft propane heater:

- Mounting & location, 12v power hook-up, minimum 20” and a maximum 56” of chimney, the location of hole for the chimney & the fuel supply.
- The fittings needed to connect to your fuel supply.
- Install of a separate low pressure regulator (11” WC).

3. Installing your Heater

Location

When installing your new propane heater, keep in mind the location of the heater and where it will maximize the heating capability. This propane heater is equipped with a 12v fan that will blow hot air from the top of the heater down onto the floor.

This increases heating efficiency and provides good circulation of hot air. Mounting the heater lower will allow for more efficient circulation of heat in the cabin. Plan your heaters location prior to installing to ensure the location chosen will fit the specifications and safety clearances.

Safety Clearances: Above- 20", Front- 18", Sides- 2", Below- 2"

Combustible material such as the deck/ceiling or walls that are closer to the heater than the specified safety clearances must be insulated with insulation or millboard with a metal liner, a .5" standoff is best for air movement behind. Another alternative is using insulation or millboard and ceramic tile.

Mounting

Secure the heater mounting plate directly onto the mounting surface. No additional insulation is required. Use appropriate fasteners for mounting.

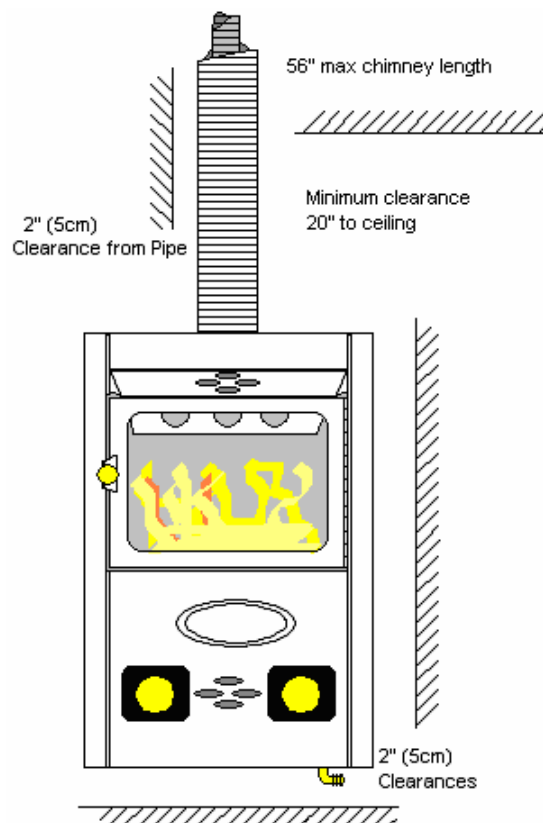

Chimney Pipe

The stainless double walled flue pipe that is included with the heater is 28" (71cm) long. Four springs are between the inside and outside pipe to ensure that an even air space is provided. It is important that two springs be located at any bend in order to prevent the pipes from touching.

Extensions are available in 10" (25.4cm) part# 19-005 and 28" (71cm) part# 19-000. The maximum total length of the flue exhaust pipe can be 56" only. Locate your heater so the distance between the heater and the pipe conform to the available pipe lengths.

We do not recommend you cut the pipe but the pipe can be cut with a fine hacksaw blade to the required length. To do so, twist the pipe to tighten the pipes flexibility, then tape the end of the pipe and install a hose clamp on the side of the pipe that you are keeping. This is so the clamp is left on the pipe and only removed after or during installing. Cut with fine tooth hack saw blade then use a round file to remove the large burrs in the inside of the pipe. Use caution as the flexible pipe can be easily damaged.

Locate and run the vent pipe such that no low points occur where water or debris can accumulate and thus block the exhaust or intake. The direct vent chimney is flexible and can be bent to provide any angle of offset. The chimney pipe can also exit horizontally.

If you want a horizontal exit with the chimney pipe, the heater will work satisfactory if the full length of the pipe supplied (28" / 71 cm) is used to achieve the 90 degree angle. When making a bend in the chimney pipe, make the bend gradual so you don't have hot spots in the pipe when operating. When bending the pipe, don't have the bend go downwards as this will affect the draft. See diagram below. Use **caution** with bending the pipe to not collapse or damage it. If the pipe needs to be cut, use extra **caution** so the pipe doesn't unravel.



Deckfitting and Exhaust Cap

- Step - 1** Measure, cut or drill a 3" hole through the deck, ceiling or wall where the exhaust cap will be located.
- Step - 2** Make sure the sealing gasket is installed under the above deck-flange before screwing down the fitting. Rotate the pipe so that it is not visible. Holding the deck flange firmly in position and secure with the 6 stainless screws supplied.
- Step - 3** Attach the dress ring on the inside, underneath the fitting with the 4 stainless screws supplied. (Make sure that the opening lines up with the underside of the deckfitting or the pipe will not fit correctly).
- Step - 4** Install the flexible pipe on the heater. It is very important that the small pipe fit tightly against the flue collar on the heater (even adding some muffler tape or tin foil to fill in any gaps of the pipe to ensure an airtight connection, the cap and any other connections are not as important).
- Step - 5** Make whatever bends are necessary in the flexible pipe and push into the deckfitting.
- Step - 6** Attach the back mounting plate and secure the heater in position.

WARNING: Do not install the external flue cap within 20 inches (500mm) of a refueling fitting or fuel tank vent.

NOTE: If the cap is positioned close to an edge where it can get an upward wind then it may give some turbulence to the air intake. If this position is in the best spot then consider the cap guard part# 19-080 that has a shield to block the upward winds.

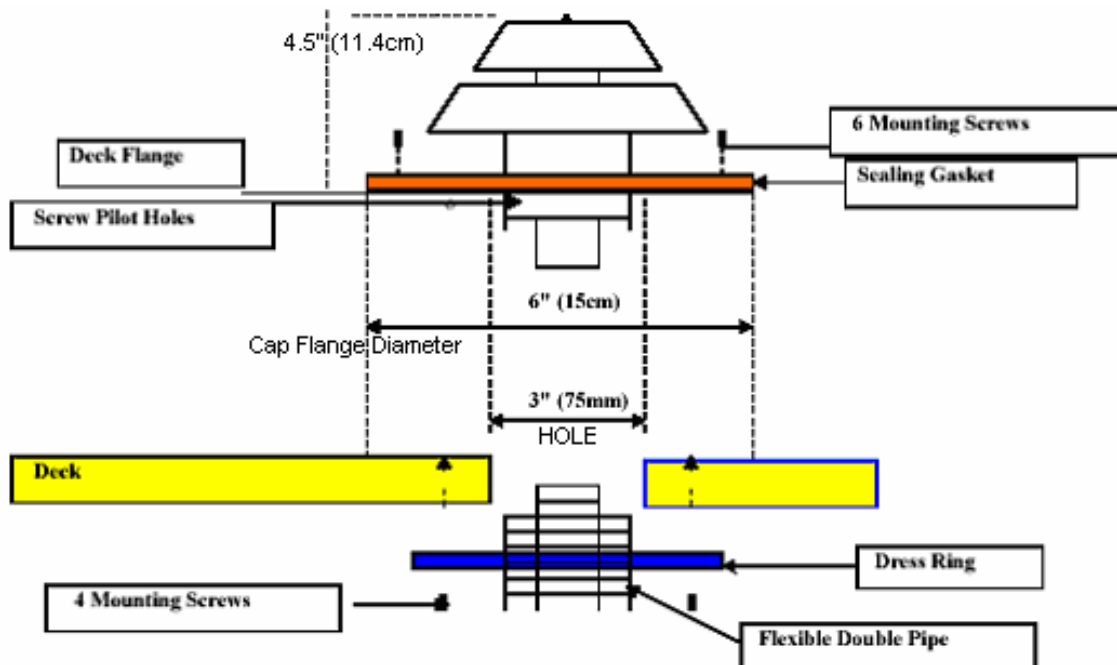

4. Connecting the Propane Fuel

This is a low pressure propane appliance. Do not use high pressure propane. The heater only operates on low pressure propane (11' WC or 27.4 mbars) and should have a low pressure regulator (part# 19-151) installed within the fuel line. The propane gas connection can either come from an already installed propane system, a single 10 or 20 lbs tank or a 1 lb disposable bottle. The propane tank should always face upwards. To run the fuel to the unit, copper tubing or a rubber approved hose can be used. The size of the fuel line should be no smaller than 3/8" in diameter. When running the fuel line, make sure the ends are sealed so no debris can get inside the line. This can block the gas coming through the heater small orifice. Make sure to blow through the fuel line before connecting.

NOTE: Each low pressure propane appliance should have its own low pressure regulator and fuel supply line as shown on the propane locker diagram on pg. 9.

Reasons for having a separate low pressure regulator for each appliance:

1. The ABYC Standards state- **1.7.2** – Each appliance shall be served by a separate low pressure regulator and supply line that shall originate inside the cylinder locker. We recommend you follow the ABYC standard.
2. The regulator only serves a very low pressure of gas, through a small 3/8" gas line, and depending on the distance, 1 regulator for 2 appliances may starve the burners of gas for 1 appliance.
3. Some older appliances do not have thermocouples on the burners, and if the gas valve on that appliance was left in the "on" position, gas would leak while using the heater or any other appliance and could result in a serious explosion.

The diagram on pg. 9 is to illustrate a typical installation only and should not be used to illustrate any particular regulatory code, insurance requirement or to override manufacturer's instructions on any fittings or components.

Install your propane system in accordance to local, national or industry specific regulations. Retain the installation and owner's manual for your gas components such as the solenoid and regulator. Installation requirements for

some of these components vary by manufacturer. Install components as directed by manufacturer's instructions.

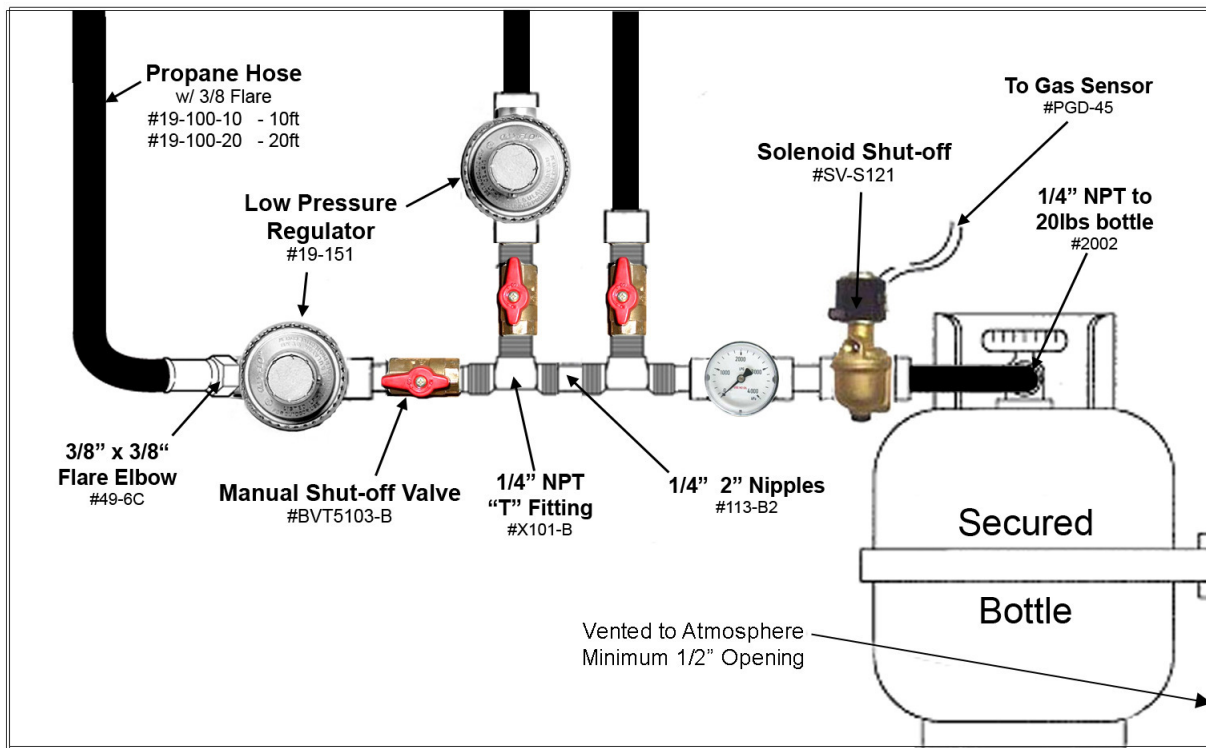

Existing System:

Part# 19-151: Low Pressure Regulator

Part# 19-100-10: 10ft Low Pressure Hose/ Part# 19-100-20: 20ft Hose

Part# 49-6C: 3/8" NPT X 3/8" flare fitting (hose to regulator connection)

(*see diagram on pg. 8 for other items you may need for install)

Single 10 or 20 lb Tank:

Part# 19-151: Low Pressure Regulator

Part# 19-100-10: 10ft Low Pressure Hose/ Part# 19-100-20: 20ft Hose

Part# 19-152: Fittings kit (hose to regulator & regulator to tank connections)

Disposable 1 lb Bottle:

Part# 19-150: Disposable bottle kit (includes regulator #19-151)

Part# 19-100-10: 10ft Low Pressure Hose/ Part# 19-100-20: 20ft Hose

WARNING:

- Never connect this heater directly to the propane/LPG supply. This heater requires an external regulator that is not supplied.

- After the gas connection is hooked-up, test all gas lines and connections for leaks with a soap solution. Test all lines and fittings before the heater is lit for the first time.

Propane Locker Caution Plate Installation

Install your propane locker CAUTION plate on or inside your propane locker for important safety reminders.

Electrical 12v Fan

The fan inside the heater is 12V DC .17 amps and the power supply must be brought to the wire connectors of the fans ON/OFF switch through the grommet installed at the bottom of the heater. The fan installed in this heater is CE approved and EM compliant for FCC and CSA regulations. The fan must have an inline fuse rated at 2 amps.

If applicable, this appliance must be electrically grounded in accordance with local codes or in absence of local codes, with the *National Electrical Code, ANSI/NFPA 70*, or the *Canadian Electrical Code, CSA C22.21*.

NOTE: Since this fan has such low amperage, when turning on, turn to the high setting first to get the fan blades moving, then turn it down to low if desired.

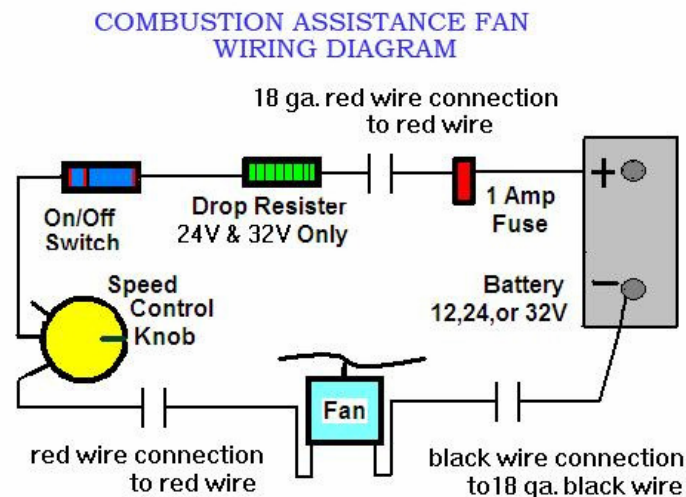

5. Lighting Procedure

- 1) Open heater door
- 2) Turn GAS knob to LOW only as the high setting will not work when lighting.
- 3) Press knob and light burner manually (It may be necessary to keep clicking the lighter in order to keep the flame going to overcome the strong draft).
- 4) Keep knob pressed in and close heater door VERY SLOWLY as it may want to go out when the door is almost closed.
- 5) Release knob after door is closed and flames should remain lit. Leaving the heater door open after ignition could cause the flame to go out when the knob is released. Should the flames go out then turn off the gas control valve and wait a few minutes to cool, then start over.
- 6) The HIGH setting may be selected after a minute or two of warm up.
- 7) Use of the blower fan is optional but greatly enhances heat output and hot air circulation. It is best to use the fan at about 1/2 speed.

WARNING: DO NOT touch the heater during operation as the glass window, external surfaces and the vent pipe of the heater get very hot and can cause burns. NOT closing the door of the heater properly may cause:

- depletion of oxygen within the cabin
- exhaust gas to enter the cabin, possibly including Carbon Monoxide.

Carbon Monoxide (CO) is a colorless, tasteless, invisible toxic gas, which can cause serious health problems or death. NOTE: Only on first lighting, the lubricating oil on the stainless steel pipe will produce smoke and burn off. THIS IS NORMAL. We suggest that windows and hatches be opened. Smoke from the inside pipe will be emitted outside, through the flue cap.

Flame Characteristics

When lighting the heater, the flames will create a roaring sound for about 5 minutes until the direct draft system stabilizes and reaches the operating temperature. Initially the flame is extremely blue and vibrant. After a short period of time the flames will increase in size and become less vibrant with more yellow tips. This will create more of the fireplace effect.

At the high setting the baffle at the top of the combustion chamber will glow red. This is normal and maximizes the efficiency of the heater.

5. Maintenance

To keep the heater operating safely and trouble free, it is recommended to periodically perform the following simple inspections:

1. Clean the outside of the heater to maintain the shining appearance of the stainless steel. Use a soft, non-flammable cleaning agent.
2. Refrain from using steel wool or any metal abrasive as this leaves impurities behind.
3. Inspect the propane supply system and tank for age and wear.
4. If the flame is becoming lower and lower over time or suddenly becomes very low, inspect the orifice of the heater. Accumulations of dirt and moisture inside the orifice can build over time and can be removed if they obstruct the orifice.

Thermocouple and Orifice Cleaning

1. To replace the thermocouple or cleaning the orifice on the heater the front cover must be removed. Remove the brass knobs with a 5/64 Allen wrench along with the nuts holding the black plates.
2. Next remove all the screws on the sides of the heater (careful- hold on to the front cover and remove the top and bottom). Open the door wide and pull back slightly from the front cover to remove the 2 connectors on the rocker switch (use needle nose pliers).
3. Using a 5/16 wrench disconnect the brass nut at one end of the thermocouple, located on the back of the control valve. The other end of the thermocouple is located on the front just below the door opening and a little to the left. Remove the 2 Robertson (square) socket screws and take out the old thermocouple.
4. Connect the new thermocouple to the little bracket and re install it to the front panel making sure the thermocouple is in as deep as it can be mounted to insure the flame will burn close enough to the tip. Install other end into the back of the valve. This is not a part of the propane system so no need to worry about leaks.
5. To clean the orifice, remove the copper fuel line at the front of the heater just below the door opening, then loosen the lock nut and remove the brass

fitting from the heater. The orifice is located in the brass fitting. Clean the hole with a wire smaller than a paper clip or try compressed air. Assemble in reverse order. Use locktite or similar on the brass fittings for vibration purposes.

Troubleshooting

WARNING: WHAT TO DO IF YOU SMELL GAS

- Shut off gas supply.
- Do not try to light any appliance.
- Do not touch any electrical switch; do not use any phone in your vessel.
- Leave the boat and ventilate with the appropriate equipment.
- Locate the cause of the leak and repair.

Problem	Remedy
No gas to burner on lighting	Check gas supply, regulator, solenoid
	Check that knob is exactly on LOW which is 9 o'clock when pressed in.
	Orifice is clogged due to dirt build up or material in new hose installation.
Fire does not stay lit when knob released	Depress knob, light burner and almost close door. Release knob and then CLOSE COMBUSTION CHAMBER DOOR
	Check that the door seal is good
	Check that the internal exhaust pipe is installed correctly
	Loosen, clean and tighten brass nut at the thermocouple which is at the back of the gas valve.
Fireplace shuts off during use	No gas supply – check gas pressure
	Blockage of the air intake – check the vent pipe for any object, including water that may block the intake.
Fan does not work	Check power supply (12 V DC)
	Check connection of wires
	Check proper functioning of switch
	Replace fan

Gas odor even when control knob is in OFF position	1. Gas leak. See Warning. Locate and correct all leaks
	2. Check and, if required, replace the control valve. If operation is attempted with high pressure gas, the valve could fail.
Slight smoke or odor during initial operation	This is a normal event, caused by burning off of residues from the manufacturing process. Smoke and odor should stop after a few hours of operation

Propane P9000/ P12000 Fireplace Heater Accessories & Replacement Parts

- Part# 19-000: 28" Extension Kit with connecting coupling
- Part# 19-005: 10" Extension Kit with connecting coupling
- Part# 19-030: 2.5" x 18" Stainless Flue Guard
- Part# 19-100-10: 10ft Low Pressure Propane Hose
- Part# 19-100-20: 20ft Low Pressure Propane Hose
- Part# 19-150: Disposable bottle kit (includes regulator #19-151)
- Part# 19-151: Low Pressure Regulator
- Part# 19-152: Fittings Kit (hose to regulator & regulator to tank connections)
- Part# 19-080: Stainless Exhaust Cap Guard
- Part# 19-200: Weather Guard to use alone
- Part# 19-210: Weather Guard to use with part# 19-080 Exhaust Cap Guard

- Part# 01-031: Replacement 12v Fan
- Part# 01-073: On/ Off Switch
- Part# 01-074: 12v Fan Speed Control
- Part# 02-014: Replacement Thermocouple
- Part# 19-020: Replacement Control Valve
- Part# 19-050: Replacement Stainless Deckcap Fitting, Gasket & Dress Ring

*For replacement parts not shown here please e-mail us for more information. info@sigmarine.com

6. Warranty Policy

We at Dickinson & Sig Marine wish to maintain a reasonable and easy system for returns, warranty, returns and exchanges. To accomplish this, we would like to inform you of some helpful guidelines and procedures to use and follow when sending back product to the Dickinson Marine. All correspondence regarding returns, warranties and exchanges will go through the factory of Dickinson Marine in Coquitlam, BC, Canada and the product MUST be returned to this location.

Warranty

Dickinson Marine warranties all of its products for a period of one year dated from the purchase of the product by the end user with proof of purchase or a registered warranty. The warranty card should be copied for your records and returned to Dickinson to activate your warranty within 90 days of your purchase. You can also activate it online at www.dickinsonmarine.com

A copy of the warranty card must have been received or a proof of purchase must be presented to receive the warranty.

1. The customer can contact us directly to settle any warranty issues. We are pleased to help. Call us toll free 1-800-659-9768 or email: info@dickinsonmarine.com
2. If the customer is returning a complete product they see as defective, be sure the product has been assembled correctly and is being used correctly. If you are not sure please call our Technical Help Department @ 1-800-659-9768. Dickinson Marine will not provide credit for used products that are not defective. In these cases, it is best to call the factory to determine if the product is being used correctly, has been assembled correctly or is in fact defective.
3. All products being sent back to Dickinson Marine must have a Return Authorization Number. Contact us at Dickinson Marine toll free 1-800-659-9768 or e-mail info@dickinsonmarine.com to obtain a Return Authorization Number. This allows us to track and process your return. Once you have received an RA# from us, include your proof of purchase and ship to the address below. We recommend you

ship using the mail service insured and retain a tracking number. Customers are responsible for the shipping costs for all returns and exchanges.

Sig Marine Returns
Unit# 101-17728 66 Ave
Surrey, BC
V3S 7X1 Canada

4. Products that are demonstrably older than the warranty period or those that have obviously been misused will not be returned, exchanged, or repaired.

Non-defective Returns & Exchanges

Dickinson reserves the right to apply a 20% restocking fee for returned product sent back. An RA # will be needed from the factory to facilitate any return. Credits will be made at the last purchased price for that part number.

Limited Warranty

WARRANTY PROVISIONS: Dickinson warrants this product to be free of defects in workmanship and materials for a period of one year. This warranty is limited to claims submitted in writing within a one-year period following the date of purchase. If any part of your new product fails because of a manufacturing defect within the warranty period Dickinson offers to replace said parts free of charge, provided, however, that such parts have not been improperly repaired, altered or tampered with or subjected to misuse, abuse or exposed to corrosive conditions. This warranty, however, is limited by certain exclusions, time limits and exceptions as listed below. Read these limitations and exclusions carefully.

TIME LIMIT: This warranty is given too and covers only the original purchaser. Coverage terminates one year from the date of purchase for parts replacement.

EXCLUSIONS : This warranty does not cover or include : (a) Any normal deterioration of the product and appearance of items, due to wear and/or exposure; (b) any guarantees, promises, representations, warranties or service agreements given or made by an authorized distributor or other person selling this product, other than those specifically stated herein; (c) any damage or defect due to accident, improper repair, alteration, unreasonable use including failure to provide reasonable and necessary maintenance, misuse or abuse of the equipment, or exposure to corrosive conditions. This warranty is conditioned upon normal use, reasonable and necessary maintenance and service of your product, and written notice being given promptly upon Buyer's discovery of a warranty claim, pursuant to paragraph 6 below. Reasonable and necessary maintenance is

maintenance which you are expected to do yourself or have done for you. It is maintenance, which is necessary to keep your product performing its intended function and operating at a reasonable level of performance.

DAMAGE LIMITATION WARNING : IN NO EVENT SHALL Dickinson BE LIABLE FOR ANY INCIDENTAL OR CONSEQUENTIAL DAMAGES, INCLUDING (BUT NOT LIMITED TO) LOSS OF USE OF THE PRODUCT, LOSS OF TIME, INCONVENIENCE, EXPENSES FOR TRAVEL, LODGING TRANSPORTATION CHARGES, LOSS BY DAMAGE TO PERSONAL PROPERTY OR LOSS OF INCOME, PROFITS OR REVENUE.

ORAL OR IMPLIED WARRANTY LIMITATIONS: The foregoing warranty is exclusive and in lieu of all other warranties, written or oral, expressed or implied, including but not limited to any warranty or merchantability or fitness for a particular purpose.

TRANSFER LIMITATIONS: This warranty is not assignable or transferable. It covers only the original purchaser.

CLAIM PROCEDURE: In the event of a defect, problem or that a breach of this warranty is discovered, in order to protect any warranty rights you must promptly notify Dickinson. Give name, address, and model name, location of unit, description of problem and where you can be reached during business hours.

RESERVED RIGHT TO CHANGE: Dickinson reserves the right to make changes or improvements to products it produces in the future without imposing on itself any obligations to install the same improvements in the products it has previously manufactured.

SECOND OR SUBSEQUENT OWNER: Dickinson does not give any warranty to secondary or subsequent purchasers, and it disclaims all implied warranties to such owners.

INSPECTION: To assist you in avoiding problems with your product and to validate this warranty you are required to do the following: (a) read the warranty; (b) inspect the product. Do not accept delivery until you have examined the product with your supplier; (c) ask questions about anything you do not understand concerning the product.

OWNER REGISTRATION: Fill out the **WARRANTY CARD** within 90 days from the date of delivery. **WARRANTY: RETURN OF THE CARD IS CONDITION PRECEDENT TO WARRANTY COVERAGE AND PERFORMANCE. IF YOU DO NOT FILL OUT AND MAIL THE CARD AS DIRECTED, YOU WILL NOT HAVE A WARRANTY.**

7. Register your Warranty.....

Please register your warranty with Sig Marine. Fill out and send back the warranty registration below. Make sure to include the serial # for our records.

No warranty will be extended for improper installations. Use of any unapproved materials, equipment, or installation procedures will result in a voided warranty. Do not use any substitutes of the heaters valve, burner or fan other than the ones supplied by Dickinson. Dickinson Marine accepts no liability for any damage or loss of service resulting from unapproved modifications.

Warranty Form

I have read and understand the Limited Warranty and the entire Instruction Manual and agree to the terms and conditions. (PLEASE PRINT)

Name: _____

Address: _____

Phone: _____

Heater Model Name: _____

Heater Serial #: _____

Date of Purchase: _____

Seller's Name: _____

Seller's Location: _____

Signature: _____

This warranty form can also be filled out online. www.sigmarine.com

Sig Marine Products

#101-17728 66 Avenue, Surrey, BC

V3S 7X1 Canada

Tel: 604-574-8641

Fax: 604-574-8659

E-mail: info@sigmarine.com

Website: www.sigmarine.com

All rights reserved. No part of this manual may be reproduced without permission in writing from Sig Marine. Sig Marine also reserves the right to modify or change without notice, any materials, applications, equipment, accessories, and/or prices.

All measurements and weights are approximate.